



FlexoTech GmbH

Schlauch- und ArmaturenService

DryCon® Dry Disconnect Coupling



www.flexotech.de



Customized safety for man and environment

DryCon® Dry Disconnect Couplings has been developed in reaction to increasing safety-awareness during transport or loading of dangerous or sensitive media with the objective to make the operation of hose lines or loading arms safer, more economically efficient and more environmentally compatible.

With its user-friendly and simple handling, combined with best safety for man and environment, DryCon® Dry Disconnect Couplings allow quick connecting and disconnecting of filled hoses or loading arms without any significant loss of media.

DryCon® Dry Disconnect Couplings are available in sizes DN25 (1") to DN100 (4") and can be used in almost any industrial application due to the diverse range of material combinations.

DryCon® - DN50 (2") - KD70mm



DryCon® - DN65 (2½") - KD105mm



DryCon® Dry Disconnect Couplings are verifiably compatible with other manufacturers, such as TODO-MATIC® or DDCouplings® and thus the globally most widely distributed dry disconnect coupling principle.

A variety of leading companies from within of the chemical and petrochemical industry, offshore industry and pharmaceutical industry trust in the DryCon® Dry Disconnect Coupling system in the conveying of many different media.

DryCon® - DN80 (3") - KD119mm

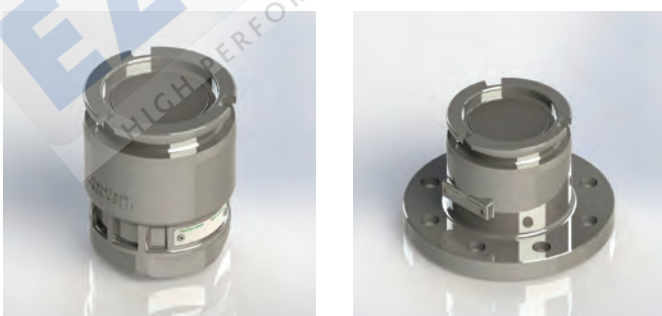

Typical areas of use:

- Loading and unloading of tank trucks or railtankers (RTC)
- Loading arm systems
- Mixing systems (exchange manifolds)
- Internal product transfer
- Ship loading - "ship/ship", "ship/shore"
- Ship refuelling
- Fuelling of locomotives
- Filling/Bottling of paints and varnishes
- Disposal of waste oils or toxic substances
- Filling/Draining of IBC-containers
- Internal distributor systems



Sizes - Diameters - Compatibility

<p>DN25 1" KD 56 mm coupling diameter</p>	<p>DN50 2" KD 70 mm coupling diameter</p>	<p>DN65 2½" KD 105 mm coupling diameter</p>	<p>DN80 3" KD 119 mm coupling diameter</p>	<p>DN100 4" KD 164 mm coupling diameter</p>
---	---	---	--	---

The coupling sizes 2" (KD70) to 4" (KD164) are manufactured in accordance with NATO STANAG 3756 and are compatible with other existing brands like DDCouplings® / TODO-MATIC® / Avery Hardoll®

Body Materials - max. Working Pressure (MWP/PN) - Temperature Range

<p>Aluminium</p> <p>DN25 (1") - DN50 (2") = PN16 DN65 (2½") - DN80 (3") - DN100 (4") = PN10</p> <p>-20°C to +80°C</p>	<p>Brass / Gun Metal</p> <p>DN25 (1") - DN50 (2") = PN16 DN65 (2½") - DN80 (3") - DN100 (4") = PN10</p> <p>-20°C to +80°C</p>	<p>Stainless Steel</p> <p>DN25 (1") to DN80 (2") = PN25 DN100 (4") = PN10</p> <p>-40°C to +80°C</p>
--	--	--

Other Material on request: eg. Hastelloy / PEEK / special alloyed stainless steel.
The temperature range is limited by the chosen sealing material.

Sealing Materials

<p>FKM - Viton®</p> <p>Standard</p> <p>-20°C to +200°C</p>	<p>EPDM</p> <p>-50°C to +140°C</p>	<p>NBR - Perbunan®</p> <p>-25°C to +120°C</p>	<p>FFKM</p> <p>ex. Chemraz® / Kalrez®</p> <p>-30°C (-40°C) to +260°C</p>
---	---	--	---

Other sealing materials on request: ex. Viton® GF / HNBR - Therban®.

Viton® and Kalrez® are registered trademarks of DuPont Performance Elastomers. Perbunan® and Therban® are registered trademarks of Lanxess Deutschland GmbH.
Chemraz® is a registered trademarks of Greene Tweed & Co. GmbH.

Connections

Thread Connection		Flange Connection		
DIN ISO 228-1 / BSP	NPT - ANSI B.2.1	EN1092-1	ASA ANSI B16.5	TW DIN28459
				TTMA

Other connections on request: eg. S60 x 6 (IBC) / excentrical flanges / Tri-Clamp-Flanges

Approvals - Certifications

- CE type examination and type approval according to 97/23/EG(EC) - Pressure Equipment Directive
- CE type examination according to EN14432:2006 - GGVSEB / ADR 2013 / RID 3013
- Conformity assessment procedure according to 94/9/EG(EC) - ATEX
- Compliance with the CEFIC recommendation for the distribution of Ethylene-, Propyleneoxid, Acrylnitril
- Compliance with the requirements of the NATO STANAG 3756



DryCon® - Hose Unit - Coupler

Three rollers in three cam tracks

Better linear guidance across the entire connection process. Lower concentrated load per roller.

Rollers fixed individually

Contact with the swivel sleeve is prevented. Less friction

Pressure piece with spherical guide ring and three divisional bars

Better linear guidance, smaller individual loads. Sliding elements of PTFE minimise friction.

More powerful handles

Isolation from the ball-bearing ring permits easy replacement. No direct force applied on the housing.

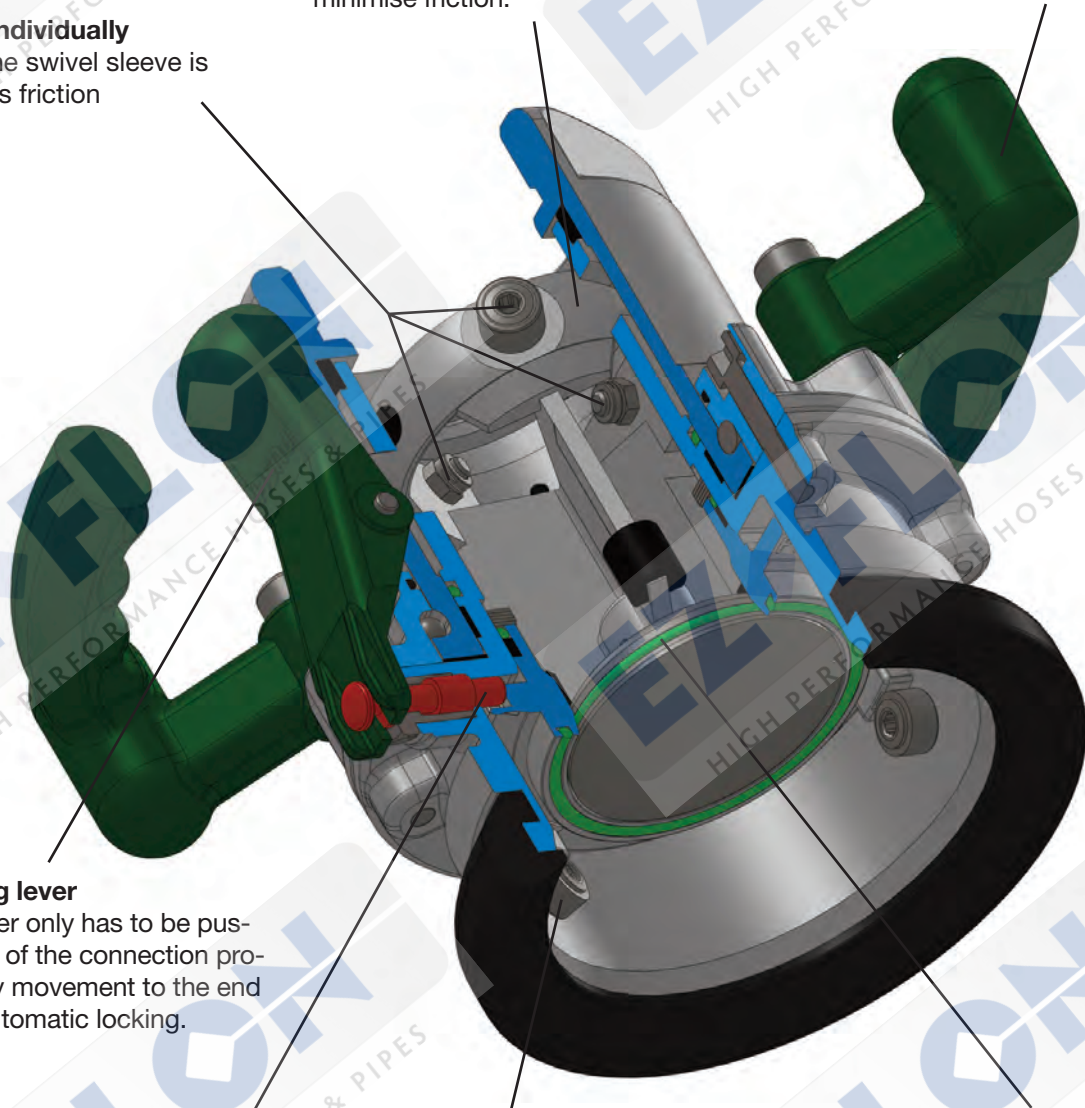

Robust locking lever

The locking lever only has to be pushed at the start of the connection process. With easy movement to the end position and automatic locking.

Locking device in both end positions OPEN (connected) and CLOSE (disconnected)

The end position is audible ("click!") and visible, due to the movement of the lever.
The open position is held even when turning forces are applied to the hose. The closed position is held and displayed. In this position, the coupling can be disconnected. Therefore damage due to excessive from turning any further, is avoided

Stainless steel locking rollers with hardened surface

Better friction properties, less active scuffing.
The hardening process improves the corrosion resistance to most media (Kolsterisieren®).

Angle seated sealing of the valve disc

No active scuffing of the sealing due to friction in a cylindrical guide.
The driving plate stays in a sealed position in event of broken locking rollers.



DryCon® - Tank Unit - Adapter

Angle seated sealing of the spring loaded valve disc
No active scuffing of the sealing due to friction in a cylindrical guide. Metal sealed in the event of seal failure. Valve disc stays in position up to the bursting pressure.

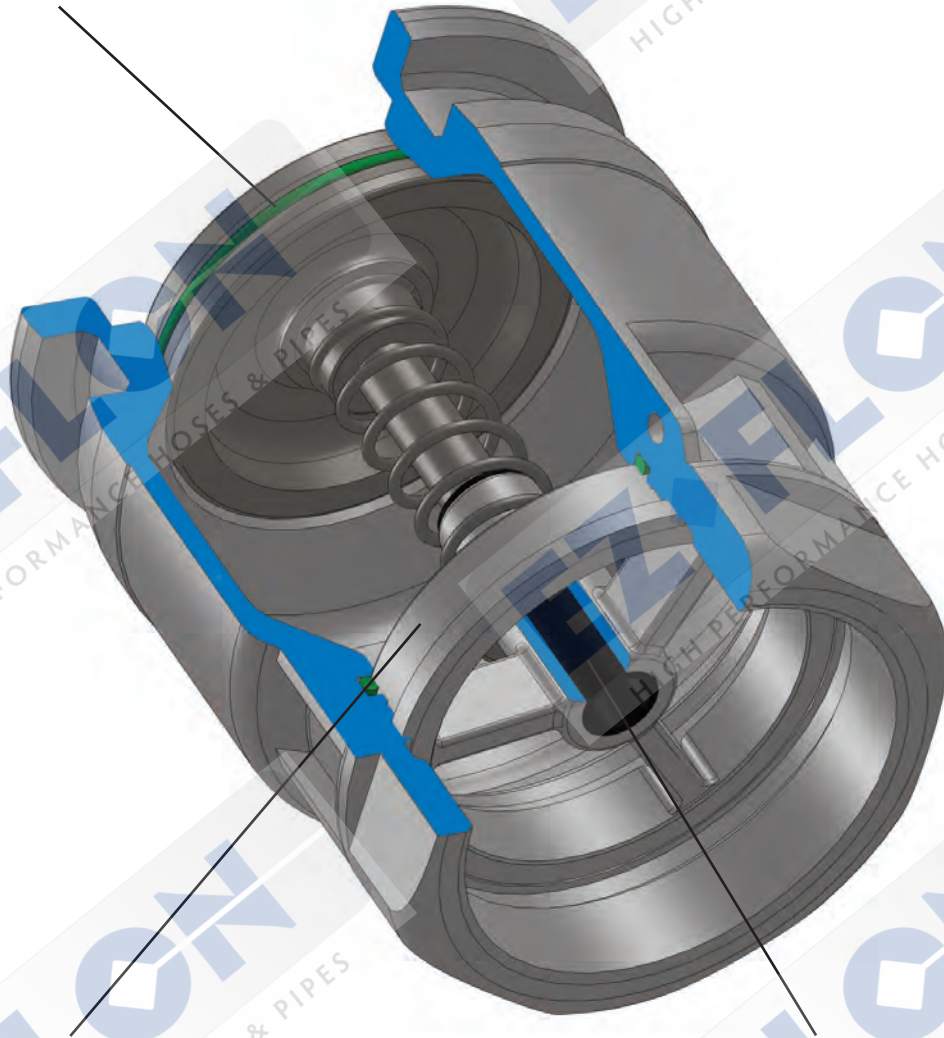

Screwed-in valve guide form-lockingly connected to the housing
In the event of an operating error in the process, the valve guide will not move out of position. Powerful bridges prevent deformation.

Extra long PTFE guide sleeve
The maximum adjusted length of the guide prevents canting at eccentrically applied opening force.



Making a Connection



1. The coupler (hose unit) is pushed over the adaptor (tank unit) without canting until the three rollers - offset by 120° - of the coupler have been completely guided through the slots of the adaptor. The position is not relevant.

2. In couplers with a locking device, it now needs to be activated by pushing the locking lever.

3. A subsequent turning movement of about 100° clockwise seals the coupler and adaptor against each other in the first step and then fully opens them.

4. At the end of the rotating movement, the defined end position can be felt where the optional locking function will also engage.

The connection is now safely established.

Loosening a Connection

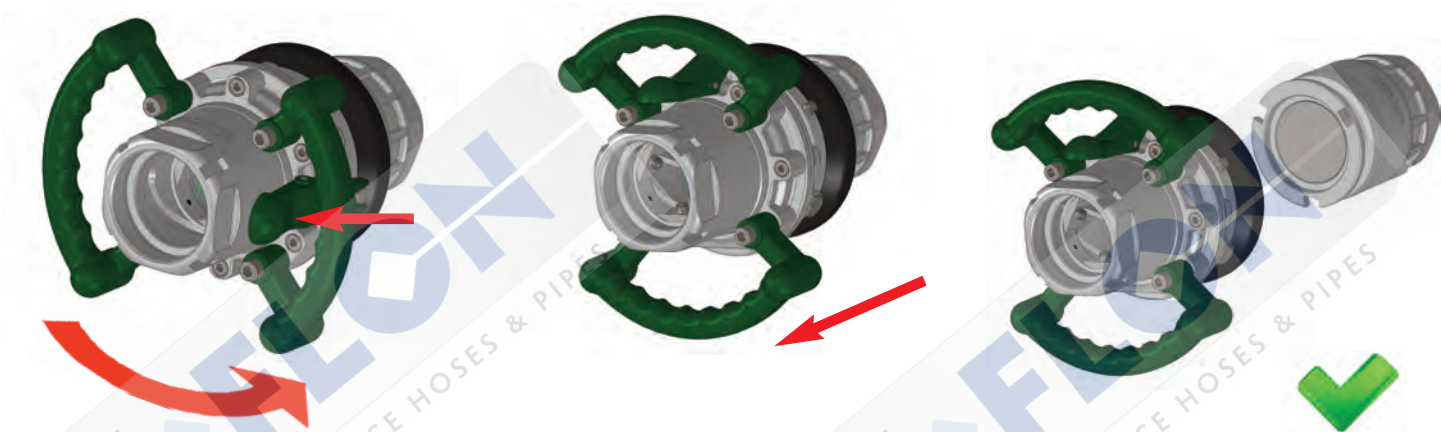

1. In couplers with a locking device, it now needs to be activated by pushing the locking lever.

2. A subsequent turning movement of about 100° counter-clockwise fully closes the coupler and the adaptor in the first step and then loosens them.

3. At the end of the rotating movement, the defined end position can be felt where the optional locking function will also engage.

4. The coupler is now pulled from the adaptor completely without canting.

5. The couplings are now disconnected.

The connection is disengaged.



Basics - General

All DryCon® Dry Disconnect Couplings can be adapted with a selectivity to prevent inadvertent mixture of media in "wrong coupling processes". Mixing may cause contamination of the transported medium and, in severe cases, dangerous chemical reactions.

Depending on the diameter/size of the coupling, different "keys" are available. The positions of the pins (in the coupling) and grooves (in the adaptor) must match. Please observe this when choosing your couplings.

Illustration - Function



Caps and Plugs

Basics - General

We recommend using dust caps (for DCV) and dust plugs (for DCM) to protect the DryCon® Dry Disconnect Couplings from weather influences, contamination and outer mechanical damage. Pressure Tight Caps have the same function as dust caps, however additionally, they allow pressure resistance up to the max. operating pressure of the adaptor (tank unit). Approved according to GGVSEB - ADR/RID 2013, DIN EN 14432 and according to RL 97/23/EC.

Sealing cap - DCK



Pressure Tight Cap - DCK-D



Dust Plug - DCS

